

IL Rte 22 to Gilmer Road

Public Informational Meeting #2 – July 13, 2017

PROJECT OVERVIEW

Due to the poor condition of the existing pavement, the Village of Long Grove requested and secured federal Surface Transportation Program (STP) funding for improvements to North Krueger Road between IL Rte 22 and Gilmer Road. This improvement was proposed to consist pulverizing the existing base and constructing a new pavement travel surface on top which would include paved shoulders from Krueger Court north to Gilmer Road. Surface Transportation Program funds awarded by the Lake County Council of Mayors will cover 80% of the project's construction cost when the roadway is constructed to Federal Standards.

Potential Impacts to trees and the Scenic Corridor designation for N. Krueger Road has resulted in the Village re-assessing the project and developing three alternate concepts for consideration:

IMPROVEMENT CONCEPTS

Concept A – Hybrid Option

- IL Rte 22 to 200' N. of Krueger Ct – 2-inch Resurfacing. IDOT will reconstruct this portion of Krueger Road with IL Rte 22 project
- 200' N. of Krueger Ct to Eleanor Drive – 6-in Resurfacing without paved shoulders – Village Method
- Eleanor Lane to Gilmer Road – 6-in Resurfacing with paved shoulders – Required Standard for Federal Funding
- 26 Total Trees Removed (Ribbioned in Blue Only)
- 1 Protected Tree Removed
- Village Construction Cost Share \$402,800.00

Concept B – Federal Option

- IL Rte 22 to 200' N. of Krueger Ct – 2-inch Resurfacing. IDOT will reconstruct this portion of Krueger Road with IL Rte 22 project
- 200' N. of Krueger Ct to Gilmer Road – 6-in Resurfacing with paved shoulders – Required Standard for Federal Funding
- 226 Total Trees Removed (Ribbioned in Blue & Yellow)
- 30 Protected Trees Removed
- Village Construction Cost Share \$380,800.00

Concept C – Local Option

- IL Rte 22 to 200' N. of Krueger Ct – 2-inch Resurfacing. IDOT will reconstruct this portion of Krueger Road with IL Rte 22 project
- 200' N. of Krueger Ct to Gilmer Road – 6-in Resurfacing without paved shoulders – Village Method
- 0 Total Trees Removed
- 0 Protected Tree Removed
- Village Construction Cost Share \$518,400.00

Concept A Illustrated

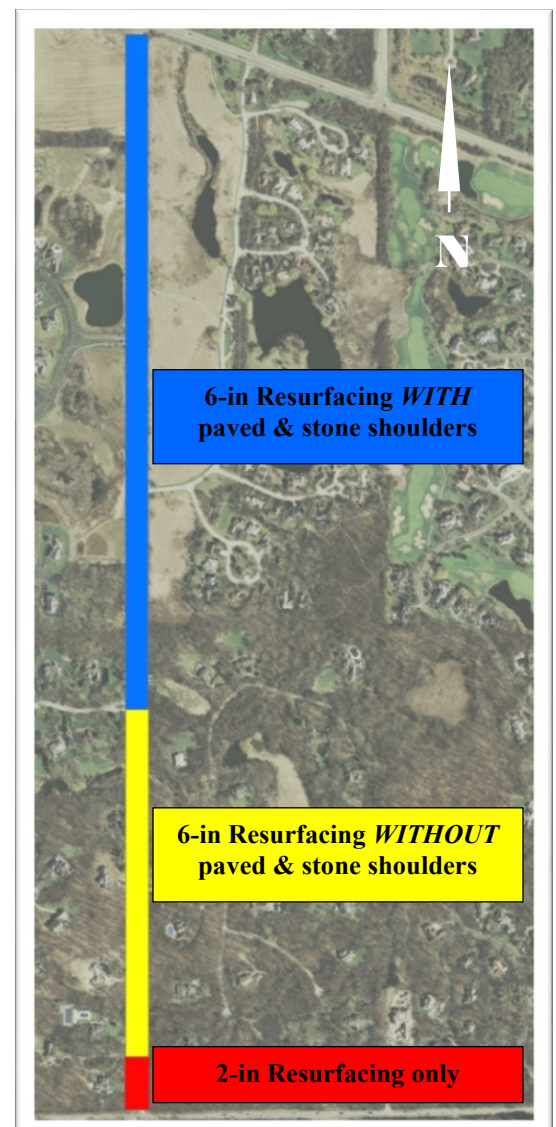

PROJECT TIMELINE

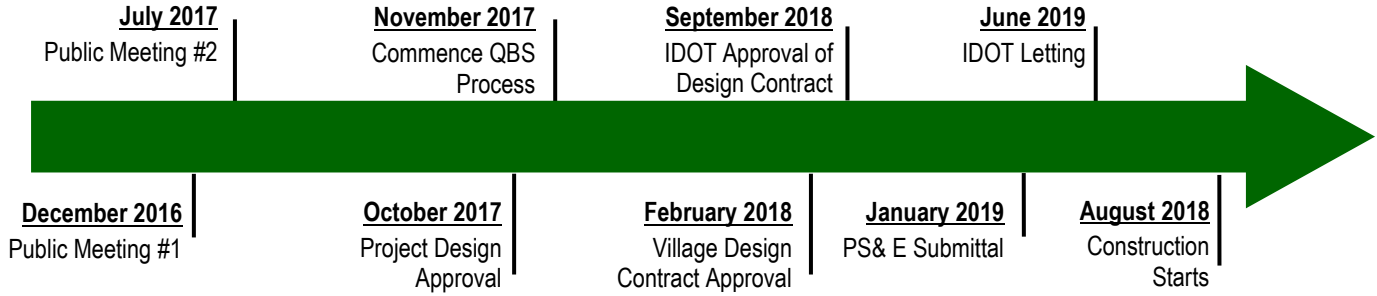

TYPICAL SECTIONS

EXISTING PAVEMENT SECTION

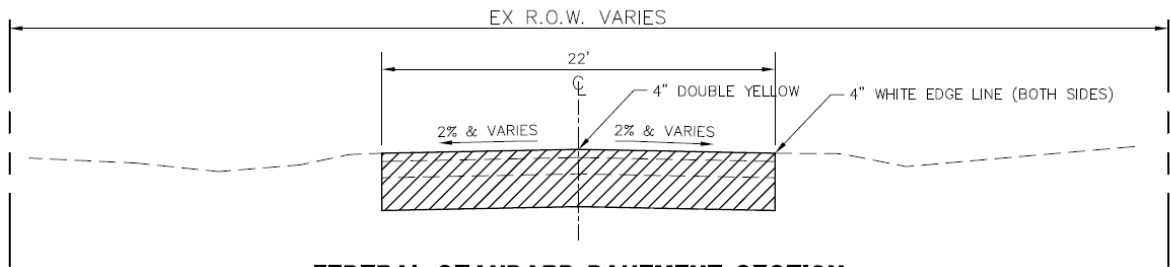

FEDERAL STANDARD PAVEMENT SECTION

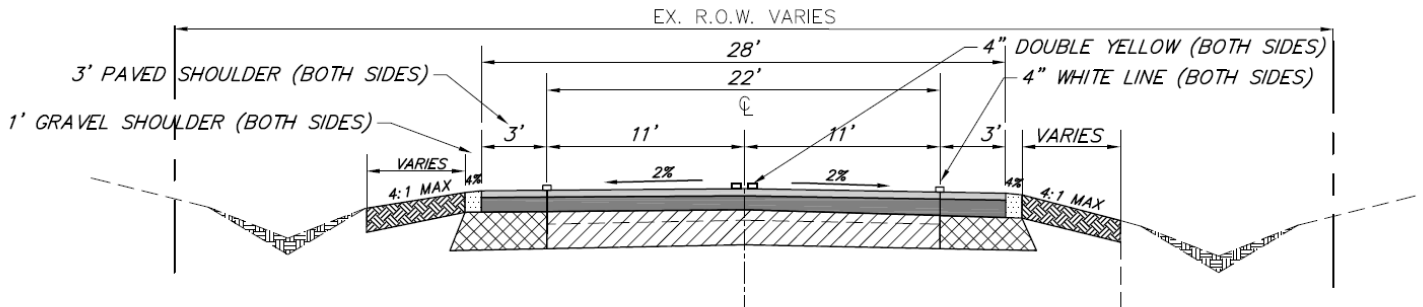

VILLAGE METHOD PAVEMENT SECTION

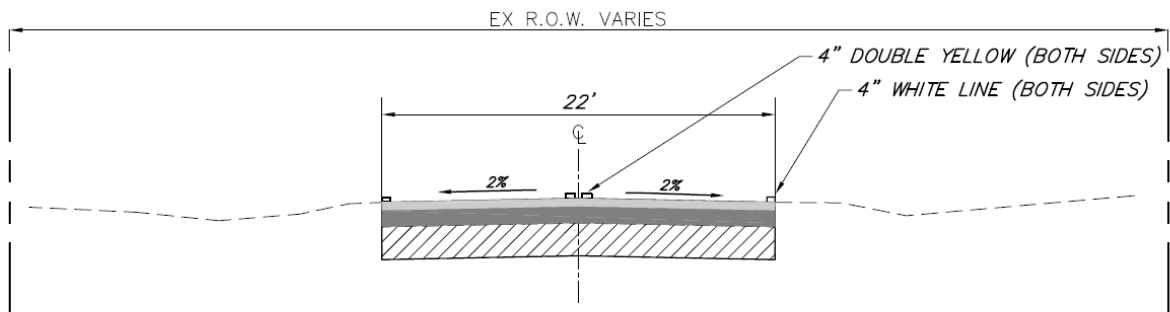

Please provide any additional comments or information requests by August 4, 2017 to:

Village of Long Grove
3110 Old McHenry Road
Long Grove, IL 60047
Attn: David Lothspeich – Village Manager
Dlothspeich@longgrove.net 847-634-9440